

5KW Water parking heater

Instruction manual

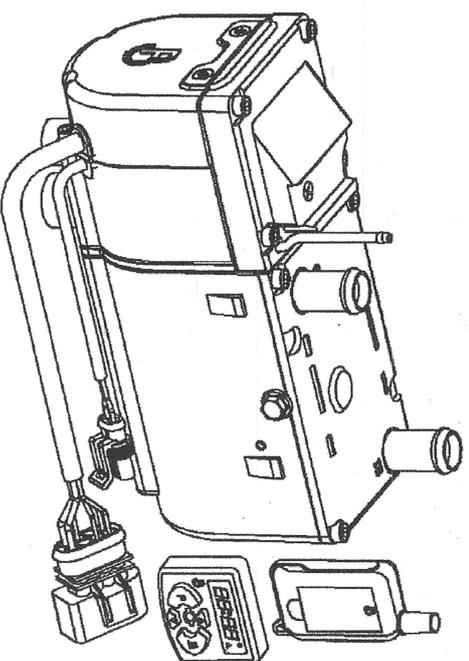

Product type	Order No.
Diesel 12V	4A1005 12C11
Diesel 24V	4A1005 24C11
Gasoline 12V	4A1005 12Q11

Water heater for operating independently of the engine.

Preface

Thank you for choosing 5KW water parking heater

This instruction book describes the structures, working principles, installation and operation of the parking heater. For correct use of the heater, please read this instruction book carefully before installation and use. The instruction book shall be saved in a convenient place for later reference.

Attention:

- This instruction book is subject to revision without notice, but the instruction book is in conformity to the purchased product.
- Our effort is to explain all questions the users may have through this instruction book. If you have any doubts or find anything incorrect in this instruction book, please contact our company directly.
- At first unpacking, please check the heater and its accessories against the packing list. Please contact the dealer immediately if any problem is found.
- If any trouble arises during application, please contact the Department of Marketing of our company or other customer service stations authorized by this company. We shall do our best to provide service to you.

Packing List(Continue)			
No.	Name	Specification	Quantity
30	Filter	RYL- I (only for diesel)	1
31	Bolt	M6×10	1
32	Self drilling tapping screw	ST5.5×25	6
33	Self drilling tapping screw	ST5.5×30	5
34	Self tapping screw	ST3×20	1
35	Self tapping screw	ST4×16	3
36	Spring washer	Φ6	2
37	Washer	Φ6/Φ12	2
38	Nut	M6	1
39	Fuel suction pipe	XYG- I 3×400	1
40	Plug	DJ7041A-2.8-21	1
41	Nylon cable ties	4×150	1
42	Nylon cable ties	4×200	1
43	Instruction manual		1
44	Reducing T	Φ6-Φ10/Φ10	1
45	Oil pipe clip	12-14	2
46	Non-return valve	D18	1
47	Transition elbow		2
48	Fixing gear		2
49	O-ring	14.8×2.62	2
50	Bolt	M6×95	1

7 Precautions

7.1 Trial operation is necessary for the heater before it is put into normal use. If lasting dense smoke is observed or irregular combustion noise or fuel smell is sensed or overheating happens to electrical components, the heater must be turned off. Please take out the fuse, making the heater unable to operate.

The heater can only be put into use after it is tested by professional workers.

7.2 After power-on of the heater, the furnace does not ignite immediately. Ignition can only be started when the system self-testing is completed and the temperature of furnace cavity and temperature of cooling liquid are reduced to allowable level.

When the heater is turned off, the combustion supporting fan and water pump do not stop working immediately and they shall keep working for about one minute for purpose of heat dissipation

7.3 When you are going to add fuel, you have to turn off the heater in advance.

7.4 If any leakage is found in the fuel supply system, you should take the heater to an authorized customer service station for repair.

7.5 If the heater is left unused for long time, it shall be started once every month and work for ten seconds, to avoid blocking-up of pump or combustion supporting fan.

7.6 Attention: To avoid danger, when the cooling liquid becomes frozen, it is not allowed to start the heater.

7.7 If welding is carried out to the automobile, in order to protect the heater, you should disconnect the positive line of power supply from the battery and connect it to ground.

7.8 Only authorized customer service stations are allowed to provide repair and installation for the heater. It is prohibited to make repair by yourself or use non-manufacturer's parts or components so as to avoid danger.

7.9 The manufacturer shall not be held responsible for any damage to the heater if such is caused due to operations with violation against the regulations.

1 Introduction

The main equipment of environmental protective and highly intelligent remote control parking heater (hereinafter referred to as the heater) is a small fuel furnace controlled by a single-chip microprocessor. Its medium circulation system is connected with the cooling system of automobile engine. In such a way, the cooling liquid for engine can be heated by the heater while the engine is not working, so as to increase the temperature of the engine and the interior of automobile. The engine is made easy to start even at very low temperature and both the drivers and passengers can have a warmer environment.

The heater is fully automatically controlled for heating. It features in compact structure, small volume, remote control, energy-saving, environmental protection, dual security system, convenient installation, easy maintenance, etc.

2 Technical Specifications

Heating medium		Coolant	
Thermal power (W)	High power operation:5000W	Low power operation:1500W	Low power operation:2400W
	Gasoline	Diesel	
Fuel consumption (l/h)	High power operation:0.69 l/h	High power operation:0.62 l/h	Low power operation:0.27 l/h
	Low power operation:0.2 l/h	DC12V	DC12/24V
Power supply (Common battery for the engine)	at starting<100 37		
Power consumption (W)	for high power operation and 10 for low power operation.		
Working pressure(Mpa)	0.25		
Lowest working temperature	-40℃		
Net Weight (Only heater)	4.8kg		
Working height above sea level	≤1500m		
Mobile phone control (Optional)	No limitation		
Weight of Main Heater (kg)	2.6kg		
Mobile phone control (Optional)	No limitation (GSM network coverage)		
Remote control (Optional)	Without obstacles≤800m		
Temperature of coolant when warm blower is started	45℃		

3 Structures and Working Principles

The structures of the heater are shown in Fig. 1 (Without filter and damper)

3.1 Cooling Liquid Circulation System

6 Treatment of Usual Troubles

If the heater is started by an operator but it does not work properly, the operator can try the following methods for a treatment.

6.1 Turn off the heater and start it again. But pay attention. Do not re-start more than twice.

6.2 Check if the fuse connection between the battery and the heater is correct.

Protected circuit	Rated current of fuse	Rated current of fuse
Warm air blower motor circuit	DC12V 25A	DC24V
Main circuit of heater	20A	15A
Operation circuit of heater	5A	5A

6.3 If the temperature of cooling liquid is higher than 70°C, the heater can only be started after the temperature is reduced through pump circulation.

6.4 Trouble shooting can be eliminated according to the follow methods.

3.2 Furnace

The main body of furnace consists of furnace outer casing 2, furnace inner casing 2, combustor 4, etc. Fuel pump 16 draws fuel from fuel tank and send it to combustor to mix with combustion supporting air. The mixture is to be ignited by glow plug 5. The fresh air from air intake pipe 10 is blown into combustor by combustion supporting fan 1 for sufficient burning. The exhaust gas, after flowing is to be released to the air through muffler 11 by the exhaust pipe 17.

3.3 Controller

Control and monitoring on working conditions of the heater is carried out by the single-chip microprocessor-based controller 9 according to preloaded programs. The control and monitoring tasks are in the below:

Monitor the voltage of power supply and to decide if it can meet the requirements of work.

(1) Check if there is any open circuit or short circuit trouble with the combustion supporting fan, water pump, glow plug, flame sensor, overheating sensor, water temperature sensor, etc. before and during normal operation of the heater.

(2) Carry out control on voltage of power supply, conduction time and duration time of the glow plug.

(3) Carry out control on speed of rotation of the combustion supporting fan in heater's different phases of working.

(4) Adjust fuel feeding rate of fuel pump automatically according to heater's different phases of working.

(5) Determine (or adjust) working conditions of heater according to data collected from flame sensor, overheating sensor and water temperature sensor.

(6) Switch off the equipment automatically if some troubles arise during working. The equipment can be switched on again if necessary. But if the equipment has been switched off for more than a fixed number of times, the equipment will be locked and cannot be restarted. The instrument can only be put into use after the trouble is analyzed and solved by the troubleshooting and diagnosis instrument.

3.4 Sensors and Safety Protection

3.4.1 The flame sensor 6 is used to measure the temperature of the combustion chamber so as to judge if the combustion chamber has been ignited and keeps burning after the ignition.

5.4.3.3.1 Press key **P**. The display shows small digit "3" and **18:00**. The characters for hour are blinking. Use keys **Δ** and **∇** to adjust the hours for the power-on time.

5.4.3.3.2 Press key **P** again. The characters for minute are blinking. Use keys **Δ** and **∇** to adjust the minutes for the power-on time.

5.4.3.3.3 Press key **⏏** and "●" is displayed on the top right corner of the screen. It is confirmation to the set time.

5.4.4 How to preset heating time.

Heating time can be set between 1 minute and 1 hour 59 minutes.

5.4.4.1 After the power-on time is set, press key **P**. The screen will display **0:30**
▲ Now the characters for hour are blinking. Use keys **Δ** and **∇** to adjust the hours for heating time.

5.4.4.2 Next press key **P** again and the characters for minute are blinking. Use keys **Δ** and **∇** to adjust the minutes for heating time.

5.4.4.3 Press key **P** again. The present time is displayed on the screen again. The three small digits 1, 2 and 3 will be displayed on the left of the screen, indicating three automatic power-on times have been preset.

5.4.5 Immediate power-on and power-off.

5.4.5.1 In the state when the present time is displayed on screen, when you press key **⏏**, characters **0:30** **▲** are displayed on the screen. That means the heater has been started. The heating time can be adjusted to be between 1 minute and 1 hour 59 minutes immediately. With the passage of time, the time displayed on the screen will decrease too, until zero, and the heater is switched off automatically at last.

5.4.5.2 If you want to switch off the heater immediately, you can press key **⏏** to switch off the heater immediately. The present time will be displayed on the screen.

5.4.6 Checking and eliminating fault code.

Press key **P** in the heating mode, 6 pieces of breakdown information **XXXX** will be displayed on the screen, **X** indicates the breakdown number, **XX** indicates the failure code (Fault code see page 27). Use key **Δ**, **∇** to look at the failure information. Hold down key **P** and then press key **⏏**, all the failure information will be eliminated. Press key **⏏** the screen will go back to display the present time.

Note: Please press the key within 10 seconds, after 10 seconds the screen will

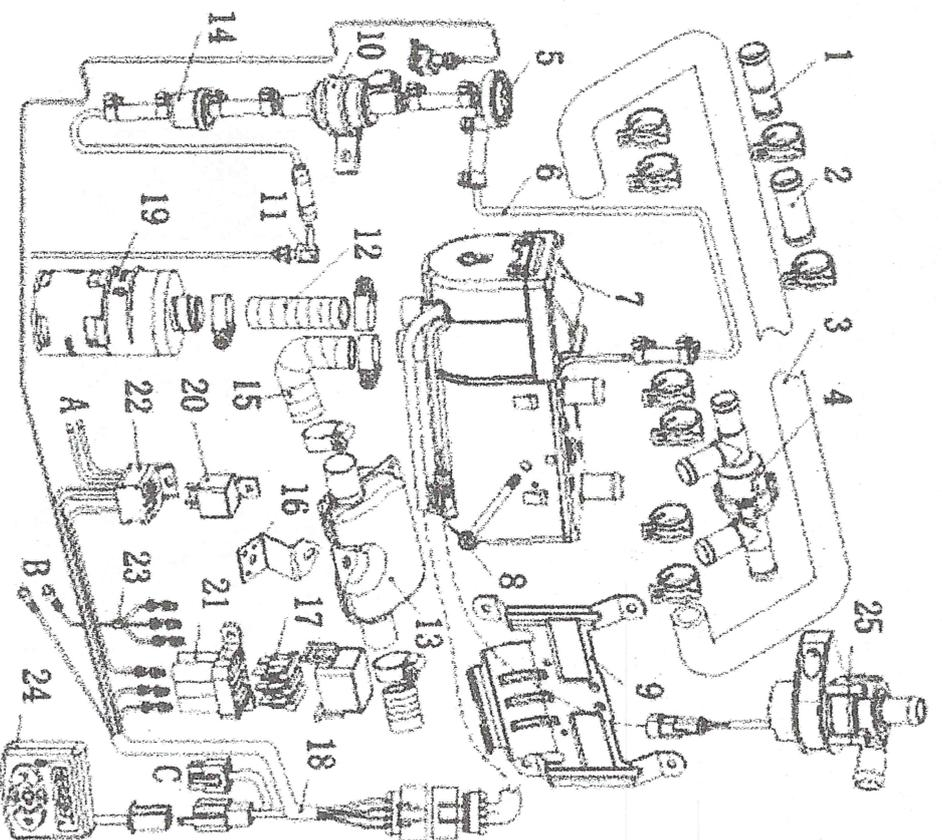

Fig.2

- 1- Water pipe joint 2- Water pipe joint 3- Water pipe 4- Non-return valve 5- Damper 6- Fuel pipe
- 7- Heater 8- Fixing bolt for heater 9- Bracket for the heater 10- Fuel pump 11- Fuel suction pipe
- 12- Air inlet pipe 13- Muffler 14- Filter 15- Exhaust pipe 16- Muffler holder 17- Fuse
- 18- Main wire bundle 19- Air filter 20- Relay for warm blower motor 21- Fuse holder 22- Socket of relay
- 23- Connect positive pole of power supply 24- Mini timer 25- Water pump
- A-Connect warm blower motor
- B-Connect positive pole of power supply
- C-Connect negative pole of power supply
- D-Connect control devices (timer, remote control and manual button)

4.1 Installation Site and Use of Heater Requirements

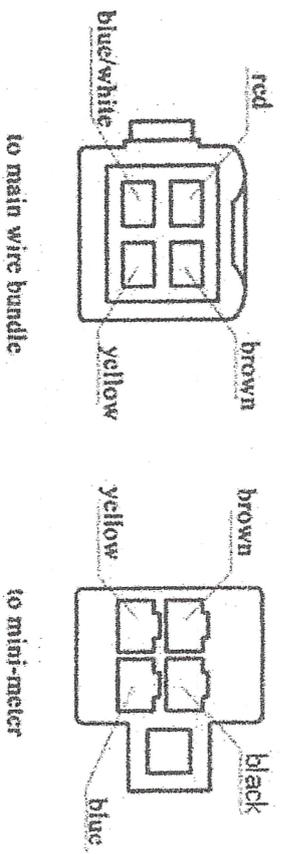

Fig. 12

5 Methods of Operation

5.1 The heater is operated by timer or a remote control unit. The timer is installed in the cab. The remote control unit consists of two parts: remote control receiver and remote controller (or cellphone). The receiver is installed inside the automobile. The transmitter is carried by the user for remote operation within a valid range.

5.2 The main modes of control on the heater include:

5.2.1 Manual power-on and manual power-off.

5.2.2 Manual power-on and automatic power-off when working time has come to a preset length.

5.2.3 Automatic power-on at preset time and automatic power-off when working time has come to a preset length.

5.3 Before turning off the engine, you should set the A/C as the warm air mode and keep I or II gear for the manual A/C, keep the A/C in "Open" position for automatic A/C. In such a way, it is convenient for heating the compartment next time.

5.4 Instructions to Operation of Timer

5.4.1 Panel functions

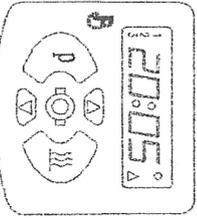

Key P: switching between functions.

Key ⏻ : To confirm or cancel the settings.

Immediate power-on or power-off.

Keys Δ and ∇ : To increase or decrease time, increase or decrease display brightness.

4.2.1 The main equipment of the heater is mounted on automobile with a bracket. Fasten the heater bracket firmly first, four corners should pad with rubber shock absorbers. In order to save installation space, can insert the M6 bolts into the fixed holes of parking heater, then hanging the heater on the support toggle hook, finally the M6 bolts tightening in the threaded holes of parking heater.

4.2.2 The heater shall be installed in the engine chamber as deeply as possible, so as to facilitate heat conduction and enable the water pump to evacuate air automatically. Choice of installation location should consider the water pipe used as short as possible, an additional water pipe is not allowed, otherwise it may affect normal work of warm air blower.

4.2.3 Choice of position for installation of the heater shall facilitate release of air from the water pipe. It is allowed to incline to suit different arrangements for installation, but deviation from the "normal installation position" shall not exceed 90°, as shown in Fig. 4. Normal position is horizon and the exhaust pipe vent down.

4.2.4 Water outlet of heater can replace for elbow according to the requirements, the o-ring must be replaced at the same time.

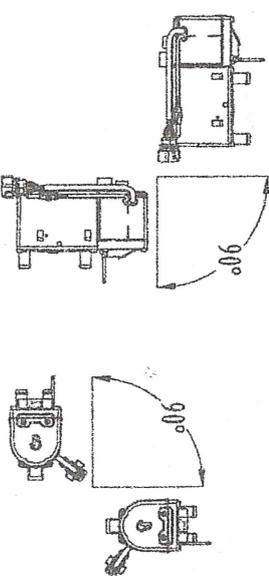

Fig. 4

4.3 Installation of Cooling Liquid Circulation System (As show in Fig.5)

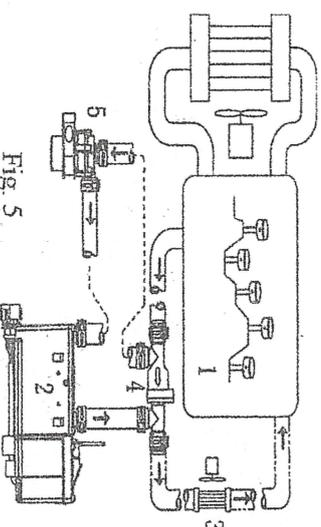

Fig. 5

- 1-Engine
- 2-Heater
- 3-Heat exchanger of warm blower
- 4-Non-return valve
- 5-Water pump

4.6.1 The wires of the main equipment of the heater for connection to outside circuits have been made into wire bundles. They can be laid according to the positions of various components and shall be fixed in some proper locations. The distance between two fixing points shall not exceed 30 cm. Attention: Any exposed wire bundle out of the automobile body or out of the wiring groove must be protected by corrugated pipe.

4.6.2 The positive line (4mm², red) of power supply of the heater shall be connected to the positive terminal of the battery of automobile. The negative (ground) line (2.5 mm², brown) shall be connected to the negative terminal of the battery of automobile.

4.6.3 Wire connections of the relay for the warm blower: The black wire of 4 mm² shall be connected to the fuse case of automobile. The black/purple wire of 4 mm² shall be connected to the “+” terminal of the warm blower.

4.6.4 All electrical components of the heater shall be connected to the wire bundles through connectors. You just need to plug in to make connections according to their corresponding relations.

4.6.5 For those components whose connecting wires may need to go through small holes (such as mini-meter and remote control receiver), you need to pass the wires through the holes before the connection is made to the connector. For such reason, the terminals of these components are not plugged in the sockets in the factory. You have to plug in the terminals according to Fig. 11. You have to keep correct relations for them. Connector for the remote control receiver: Plug connection shall be made according to wire color and serial number of terminals on the sockets. Connector for the mini-meter: Plug connection shall be made according to Fig. 12.

Attention: All terminals shall be plugged in, even for those above-mentioned components not in use, to avoid any short-circuit.

4.4.1 The function of the air inlet pipe is to draw combustion supporting air into the main equipment for the furnace. the vent of the air inlet pipe shall not be opposite to the air flow, and shall not be plugged by dust, rain or snow. The protective hood at the vent shall not be damaged.

4.4.2 The special-purpose exhaust pipe shall be cut off in proper position to form two sections: an exhaust pipe and an exhaust tail-pipe. The muffler shall be positioned in the middle and fixed with the muffler holder.

Attention: Exhaust parts are at high temperature when the heater is working. They shall be arranged far from the plastic parts and wires of the vehicle to avoid damage.

Air inlet pipe and exhaust pipe is easy to freeze in working condition and should always check whether unobstructed.

4.4.3 The exhaust (tail-) pipe shall not extrude out of the automobile contour. Its outlet position shall prevent intake of the exhaust by the air inlet pipe or convection fan (or far from the air inlet pipe and the air intake vent of the convector fan). Its outlet shall not be opposite to the air flow, and shall not be plugged by dust, snow or rain. The protective hood at the outlet shall not be damaged.

A small hole (φ2~5) shall be drilled at the low end of the exhaust pipe for condensate to drain.

4.5 Installation of Fuel Supply System

The fuel supply system for the heater is as shown in Fig.7. Damper installation should be according to the practical situation. If the packing list doesn't include the damper then it is should not be used temporarily.

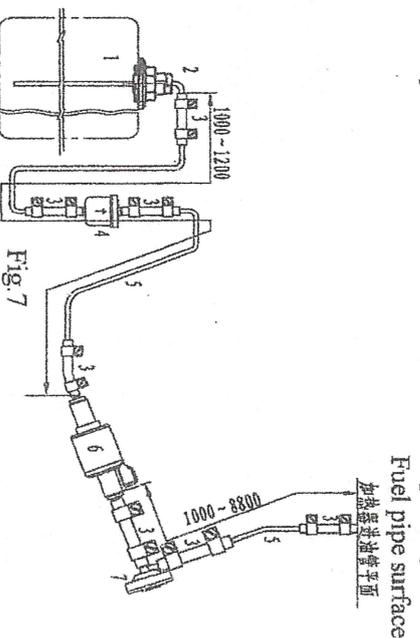

Fig.7

1. Fuel tank 2. Fuel extractor 3. Fuel pipe connector 4. Filler 5. Fuel pipe 6. Fuel pump 7. Damper
4.5.1 The fuel pump shall be fixed in automobile with a fuel pump clamp with protective rubber cover. The outlet of the fuel pump shall tilt upwards.